

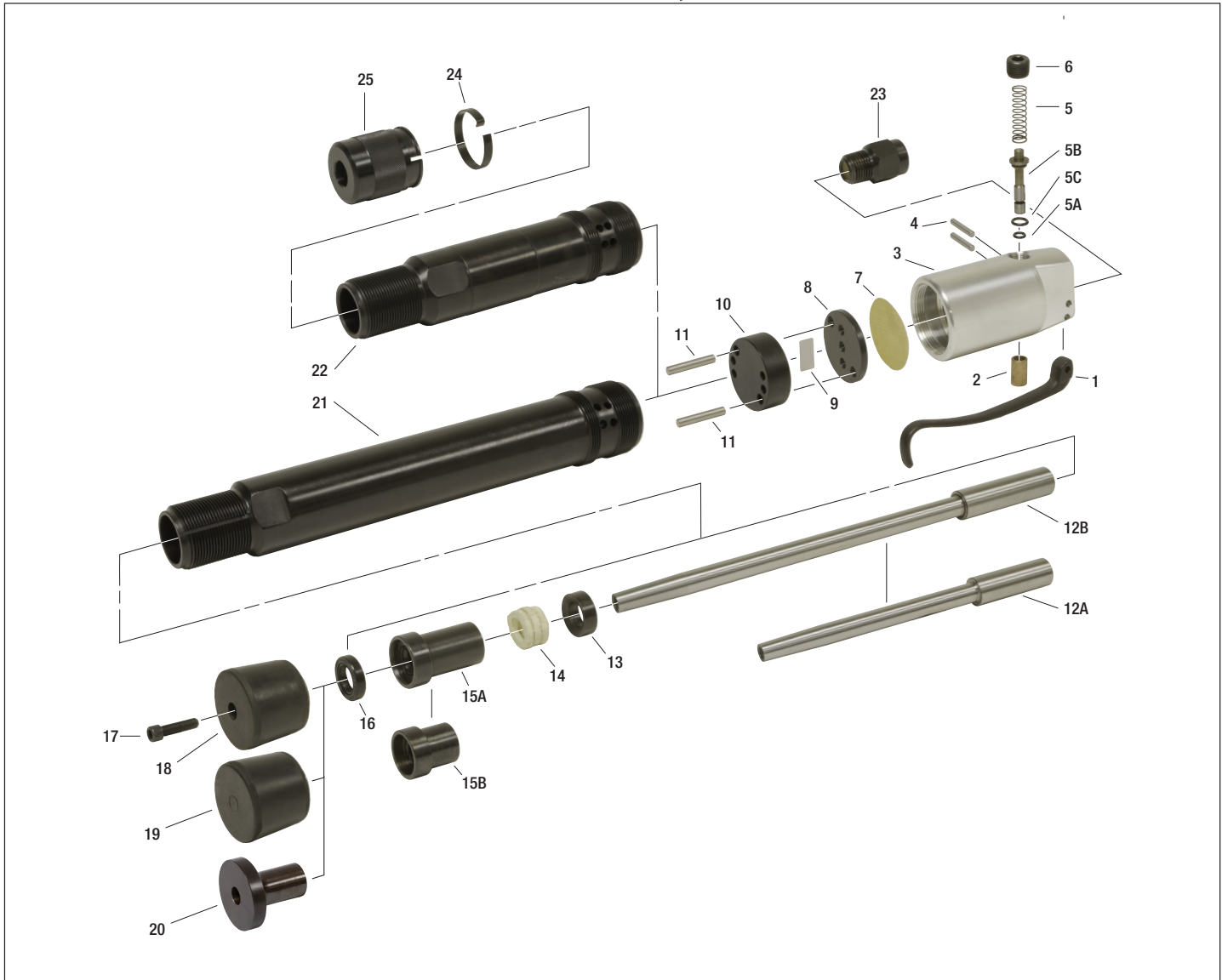

MICHIGAN PNEUMATIC TOOL, INC.

MP-BD2BA Rammer, 2-1/2" Stroke
MP-BD1BA Rammer, 4" Stroke



Index	Part No.	Description	Qty.
1	695542	Lever	1
2	695546	Throttle Valve Bushing	1
3	695539	Backhead	1
4	695773	Throttle Lever Pin	2
5	695547	Throttle Valve Spring	1
5A	OR-6227-3	O-Ring	1
5B	695545	Throttle Valve	1
5C	OR-6227-6	O-Ring	1
6	696078	Throttle Valve Spring Plug	1
7	695538	Screen	1
8	695533	Valve Block Lid	1
9	695532	Valve	1
10	695534	Valve Block	1
11	695537	Valve Block Dowel Pin	2
12A	695556	Piston w/Thread (2-1/2" stroke)	1

Index	Part No.	Description	Qty.
12B	695525	Piston w/Thread (4" stroke)	1
13	695551	Gland Washer	1
14	695552	Packing Set	1
15A	695550	Gland Bushing (4")	1
15B	695566	Gland Bushing (2-1/2")	1
16	700073	Front Rod Seal	1
17	TX-00203	Socket Screw	1
18	202-802-SP	Rubber Butt (Screw Type)	1
19	202-802	Rubber Butt (2-1/2")	1
20	TX-00202	Steel Butt (2-1/2" Threaded)	1
21	695531	Cylinder (4" stroke)	1
22	695564	Cylinder (2-1/2")	1
23	1994	Inlet Bushing (1/2" MPT x 3/8" FPT)	1
24	695553	Packing Nut Lock Clip	1
25	695549	Packing Nut	1

032613Rev3RTD | RS



MICHIGAN PNEUMATIC TOOL, INC.

Rubber Rammer Butts

Made of the finest neoprene to ensure uniformity of bonding. Highly resistant to oil and wear. Please specify tool model number and size of butt when ordering. Solid aluminum, steel and rectangular butts available.



201
1-3/4" Dia.



202
2-3/8" Dia.



203
3-1/4" Dia.



204
4" Dia.



205
5" Dia.

Part No.	Taper
201-802	802

Part No.	Taper
202-802	802

Part No.	Taper
203-802	802

Part No.	Taper
204-802	802

Part No.	Taper
205-802	802

802 Taper
MP-OB, BD2BA, BD1BA Master Power 1BA, 2BA B&D 5200, 5205 Cleco OB, 1B, 1F TX-70B, TX8-2, TX8-4

Butt Retaining Screws

Designed to retain 801, 802 and 803 series butts to the piston.



130SR-85



TX-00203

Butt Screw Part No.	Thread	Tool Model
130SR-85	5/16"-18	MP-130
TX-00203	3/8"-24	MP-OB, MP-BD1BA, MP-BD2BA, MP-241

Steel Rammer Butts



200-802
2" Steel
802 Taper



200-802-BS
2" Steel
802 Taper
Screw-Type



300-802
3" Steel
802 Taper



300-802-SP
3" Steel
802 Taper
Screw-Type

Part No.	Taper
200-802	802
300-802	802
300-802-SP	802

Specialty Rammer Butts with Screw Holes

Primarily used on MP-OB, BD2BA and BD1BA Series rammers with butt retainer screw. MPT is the only company that machines our piston to accommodate retainer bolt screws.

Rubber



202
2-3/8" Dia.



203
3-1/4" Dia.

Brass



202-802SP-BR
2-1/2" Dia. Brass

Nylon



202-802SP-NY
2-1/2" Dia. Nylon

Part No.	Taper
202-802SP	802

Part No.	Taper
203-802SP	802

Part No.	Taper
202-802SP-BR	802

Part No.	Taper
202-802SP-NY	802

Aluminum with Rubber Tip Butts



2010
2-3/8" Aluminum
with Rubber Tip



2515
3" Aluminum with
Rubber Tip



3525
3/4" x 2-3/8"
Aluminum with
Rubber Tip



4030
1" x 2-7/8"
Aluminum with
Rubber Tip

Aluminum Rammer Butts



275A-802
2-1/2" Aluminum
802 Taper



2009-SA802
2-1/2" Aluminum
802 Taper

Part No.	Taper
2010-802	802

Part No.	Taper
2515-802	802

Part No.	Taper
3525-802	802

Part No.	Taper
4030-802	802

Part No.	Taper
275A-802	802
2009-SA802	802